

HOMELAND SECURITY

Potable water monitoring for contaminants



INTRODUCTION

Chelsea Technologies Group has supplied three water quality-monitoring systems in support of the UK Government initiative for Homeland Security.



The systems are specifically designed to characterise the natural biological and physical background levels in rivers and reservoirs.

Each system is configured to measure the following:

- Temperature
- Conductivity
- Depth
- Chlorophyll-a
- Bioluminescence
- Turbidity
- Optical transmission
- Dissolved oxygen
- pH

There is an option to measure two of the chlorophyll breakdown products: phaeophytin and phycoerythrin.

Additional sensors can be interfaced to the MINI^{pack} if required at a later stage.



**For more information
contact:**

Richard Burt
Marketing Director
Chelsea Technologies Group
Email: rburt@chelsea.co.uk
www.chelsea.co.uk

NOVEL SYSTEM FOR CONTAMINANT DETECTION

Chelsea Technologies Group is working with the UK Government to assess the suitability of the Fast Repetition Rate Fluorescence (FRRF) technology for detecting the effects of hostile contaminants.

Licensed by Chelsea Instruments from the Brookhaven National Laboratory, New York it is a prime candidate for the real-time monitoring of potable water reservoirs.

Reservoirs are vulnerable to spills from farms or factories or even terrorists armed with toxic chemicals. Work at Oakridge National Laboratory, USA has found that fluorescence from water borne algae is affected by toxic chemicals. Chemicals investigated to date include methylparathion (MPT), potassium cyanide, diuron and paraquat.

- MPT is an insecticide that is structurally and functionally similar to the nerve gas sarin.
- Cyanide poisoning can cause nervous and respiratory failure.
- Diuron and paraquat are agrochemicals.

The fluorescence signal from algae in chemically polluted water is impaired compared to signals from algae in clean water. In a monitoring situation algorithms based on the rate of change of fluorescent signal are more appropriate than an absolute fluorescent measurement, as variation in algae concentration and ambient light levels will affect the absolute signal.



The approach is to measure a parameter that can be related directly to the physiology of the algae independent of environmental variations. The FRRF measurement achieves this by measuring a time dependent fluorescence signal that arises solely from chlorophyll that is active in photosynthesis.

A standard fluorescence measurement on the other hand cannot discriminate between chlorophyll that is free in the water column, present in dead algae and present in physiologically active organisms.

The FRRF response is real-time (sub-second) and concentration independent. The only factor limiting the response is the detection limit of the FRRF fluorimeter, as will also be the case with any fluorimeter making standard fluorescence measurements. The FRRF fluorimeter is actually probing the photochemistry of chlorophyll photosynthesis, one of the metabolic processes within algae that is known to be affected by both nutrients and pollutants.

SCIENTIFIC PRINCIPLES

A schematic of the photosynthesis process that occurs in aquatic microorganisms is illustrated schematically below:

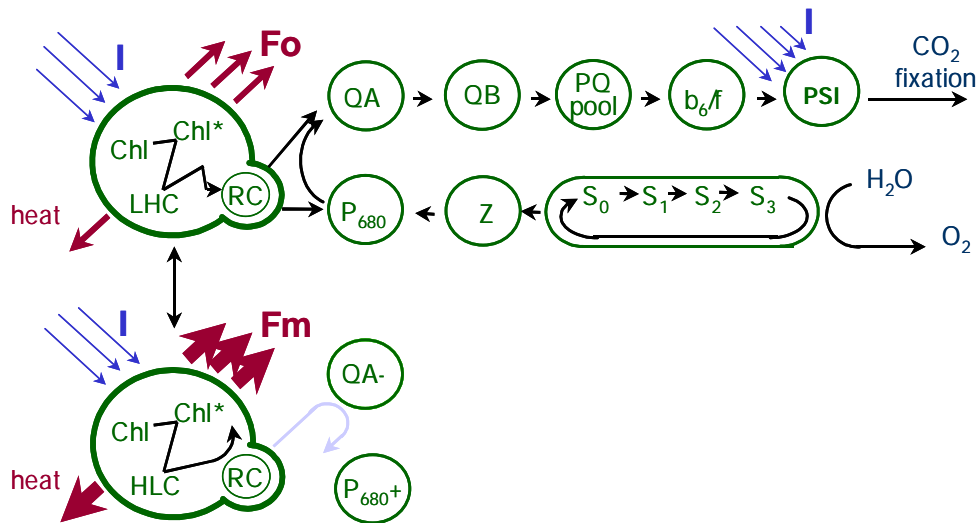

The light-harvesting complex (LHC) first absorbs ambient light (I) and the energy is transferred to the reaction centre (RC) through a number of fluorescence energy transfer steps between chlorophyll molecules. On absorbing this energy the reaction centre initiates a cycle of photosynthesis, which takes approximately $200\mu\text{Sec}$ to complete. During this time the reaction centre remains 'closed' and is unable to absorb any more energy from the light-harvesting complex, this excess energy is then dissipated as heat or additional fluorescence.

In FRRF a rapid series of $1\mu\text{Sec}$ light pulses, typically 100 pulses spaced $1\mu\text{Sec}$ apart, is directed into the water sample. Each pulse closes a proportion of the reaction centres and the detected fluorescence signal increases from an initial value (F_0) to a maximum value (F_m) when all the reaction centres have been closed. This time-dependent fluorescence signal can only arise from organisms that are photosynthetically active; chlorophyll that is either free in solution or present in dead organisms may change the value of F_0 but will not produce this so-called 'variable fluorescence'.

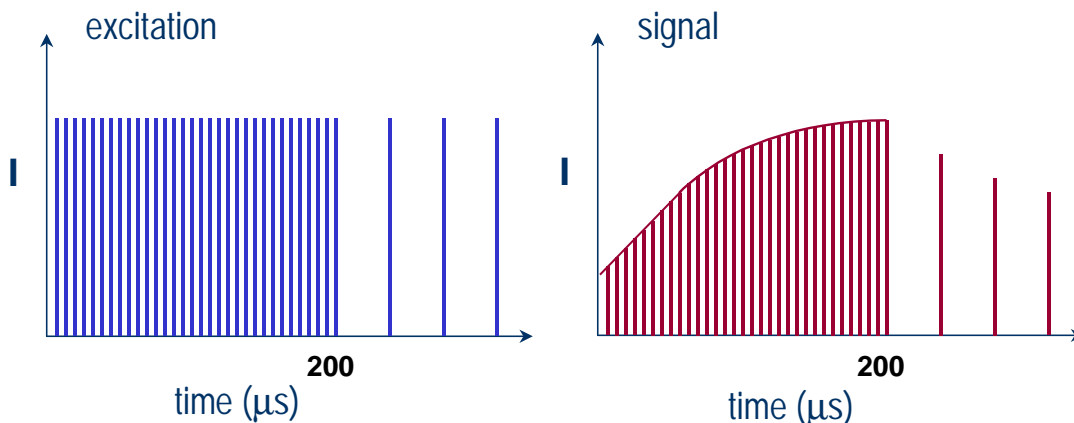

The magnitude and shape of the response (see diagram below) can be used to derive a number of important parameters that relate to the health of these

organisms and their photosynthetic activity and because of this any chemical pollutants that affect the photosynthetic process are likely to be detected using FRRF.

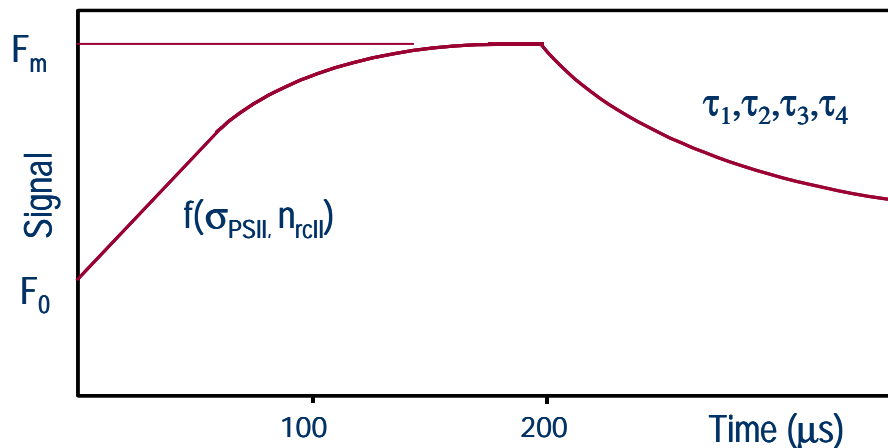

$(F_m - F_0) / F_m$: photochemical quantum efficiency (F_v / F_m)
 σ_{PSII} : efficiency of light harvesting ($m^2 \text{ photon}^{-1}$)

n_{rcII} : concentration of active reaction centres
 τ_i : rate constants of electron transfer from PSII to PSI

The most important parameter obtained from FRRF is the variable fluorescence expressed as a fraction of the maximum signal, known as F_v / F_m . This parameter is related to the photochemical quantum efficiency and can vary from very low values for organisms in a poor environment to a maximum value of around 0.65 for those in an optimal one. It is likely that pollutants or toxins will have a direct impact on this parameter and importantly, because the value is expressed as a ratio, it is independent of chlorophyll concentration.

Other parameters that can be obtained from the variable fluorescence response are the concentration of reaction centres (n_{rcII}) and the absorbance cross-section of the light harvesting complexes (σ_{PSII}). For example, in nutrient rich environments where there is plenty of light, the light harvesting complexes will undergo conformational changes that optimise their light collection efficiency and the absorbance cross-section will increase.

Again one might expect toxins to have an influence on this parameter as well as the

more obvious reaction centre concentration, which will be related to the number of living organisms in the sample.

Pollutants are also known to affect the electron transfer processes from QA to PSI (see schematic above). These occur on a longer timescale than the excitation response and can be assessed by probing the system using single light pulses spaced by approximately $40 \mu\text{Secs}$ to monitor the drop in fluorescence signal as the system relaxes back to its 'ground state'. It may then be possible to detect the influence of pollutants or toxins through a change in the time constants associated with this process.

In all cases one would be looking for a step change in any of these parameters as an indication of contamination compared to what is likely to be a gradual drift due to weather or seasonal factors.



**Chelsea
Technologies
Group**

55 Central Avenue
West Molesey
Surrey KT8 2QZ
United Kingdom
Tel: +44 (0)20 8481 9000
Fax: +44 (0)20 8941 9319
sales@chelsea.co.uk
www.chelsea.co.uk